

PreciLogger

Non Contact Thickness Measurement



- *Thickness measurement of foam & insulation and many other materials*
- *High accuracy laser measurement*
- *Full process monitoring with statistics*
- *Quick pay back*
- *More than 25 years experience*

LIMAB PreciLogger – non contact laser technology

- High accuracy even when measuring soft and moving materials
- Full process monitoring with statistics and data archiving
- Easy to install and use, can be retro-fitted to existing lines
- Increased yield, quick pay back



Improve quality – lower cost

With PreciLogger accurately monitoring the process huge gains can be made by saving material costs, reducing scrap and eliminating customer complaints or returns. This means the initial investment is recovered very quickly

Full production statistics – quality assured

PreciLogger records all product thickness and length data ready for instant access if required at a later date. In addition a convenient statistical report is also compiled summarizing the measurements over an entire reel of product or production shift. This data is also archived and can be printed on demand.



Thermally Stable Mounting Frame

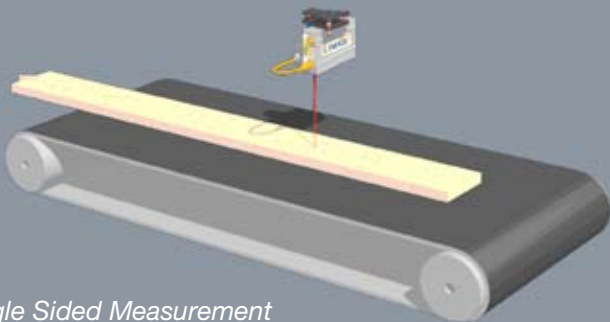

Single Sided Measurement

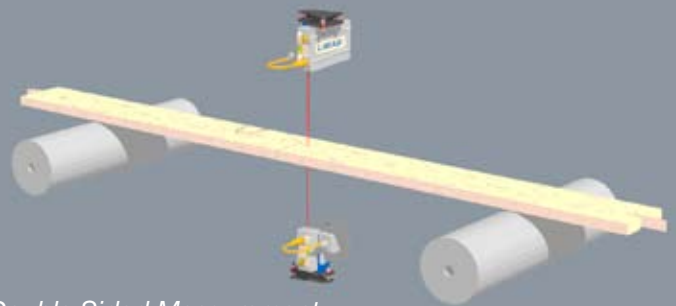

Double Sided Measurement

PreciLogger software features

- Real time numeric display of thickness & deviation
- On screen warning for alarm & pre alarm
- Product length display
- Real time graph showing thickness trend
- Product library
- User database
- Statistical reporting, min, max, mean, range, Sd, Cp & Cpk
- Data logging
- Alarm & pre-alarm outputs (requires I/O module)

Applications

- Insulation materials
- Glass mineral wool
- Rock mineral wool
- Polyurethane (PUR)
- Polyisocyanurate (PIR)
- Expanded Polystyrene (EPS)
- Extruded Polystyrene
- Rigid foam insulation boards
- Foam products
- Polypropylene foams
- Polyester fibres
- Styrofoam
- Acoustic foams
- PVC foams
- Thermoplastic foams
- Cross linked foams
- Polyolefin foams

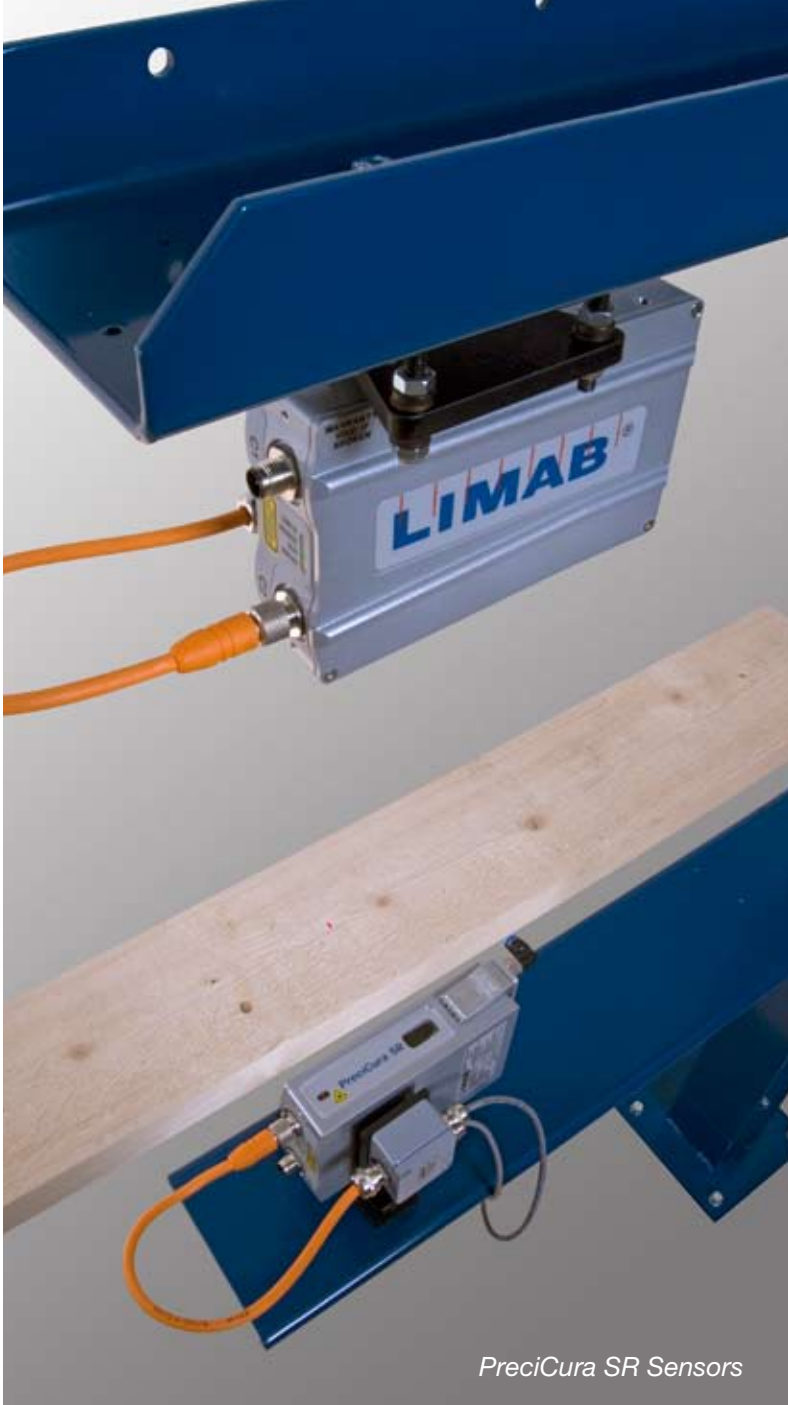

PreciCura SR Sensors

LIMAB PreciLogger

In-process thickness measurement

PreciLogger is an in-process non contact thickness or width measuring system designed to measure materials that are soft or fast moving that are otherwise impossible to measure with normal less sophisticated contact methods. The system uses LIMAB PreciCura SR/ MR laser sensors that have been proven on countless thickness applications installed around the world.

PreciLogger is a complete stand alone system which continuously monitors the production process providing 100% product inspection. The system provides the operator with a clear display showing the measured dimensions and trend graph, alarms will warn if the measurement exceeds tolerance limits. In addition production statistics are compiled for a complete batch and are displayed or printed on request. All the measurement data is archived and can be accessed later for quality assurance purposes.

PreciLogger has been developed to meet the needs of the foam, rubber and insulation material producers but it is also suitable for many other types of hard materials such as wood based panels or laminates. This means that these types of materials can now be accurately measured on-line saving time and ensuring customer satisfaction by eliminated rejects due to incorrect caliper.

Thickness of products such as glass wool, mineral wool and various foam materials can be measured by monitoring the product height relative to the conveyor bed. This method uses a single PreciCura sensor making an even more economic solution.

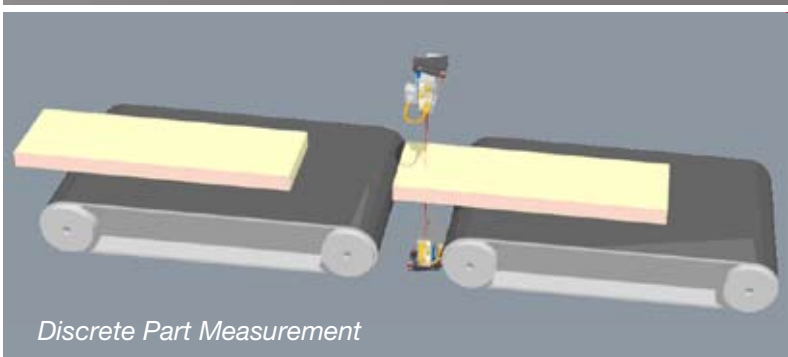

Discrete Part Measurement

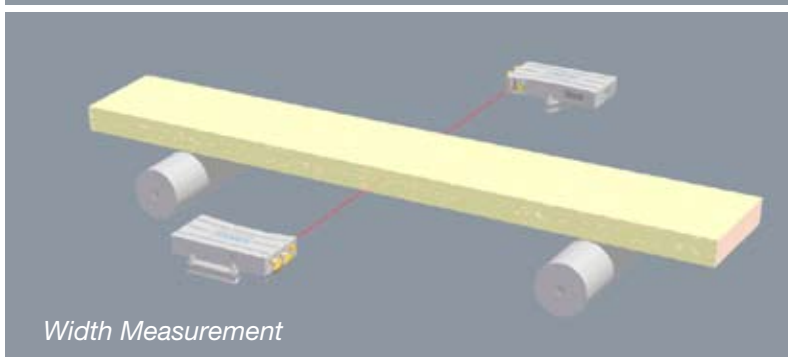

Width Measurement

Applications Other

- Rubber
- Laminated materials
- Fireproof materials
- High temperature fibrous insulation materials
- Composite building panels
- Wood based panels
- MDF, OSB, Ply
- Calcium silicate board
- Composite materials

Width Measurement

The PreciLogger system is also used for measuring width of products in-process. It is even suitable for materials that have large variation in widths such as building materials or insulation panels that are typically produced in widths from 600 -1200 mm (2-4') This is due to the large range of the PreciCura MR sensors and means it is

possible to measure directly to all product sizes without any configuration or recalibration. The PreciLogger system can be used with either the PreciCura SR or MR sensors depending on the application.

Technical specifications

Sensor

Measuring range
Stand off
Resolution
Typical system accuracy (SR)*
Sampling rate
Laser power
Laser wavelength
Laser class
Operating temperature
Protection class
PC operating system
Outputs (requires I/O module)

Isolated inputs (requires I/O module)
PreciCura interfaces

File format stored data
* Accuracy depends on application and installation details consult LIMAB for more information

PreciCura SR or

200 mm, (7.8")
100 mm, (3.92")
0.01 mm, (0.4 thou)
 ± 0.05 mm (± 2 thou), $\pm 2\sigma$,
2000 Hz
<1 mW
670 nm
(IEC825) 2
0-40°C (32-104°F)
IP 65 (NEMA 4X)
Windows XP
6 relays, high alarm, low alarm, high pre-alarm, low pre-alarm, ok and system ok
Start/stop, length counter
RS232 cable length up to 10 m or CAN-Bus for longer cable lengths
Data csv, summary txt

[PreciCura MR]

[500 mm (19.7")]
[200 mm (7.9")]
[0.1 mm (4 thou)]

Accessories

Thermally stable mounting frame
I/O module – 6 relay outputs, 2 inputs
Air purge kit to keep optics clean in dusty environments
Length counter
CAN-Bus to USB interface
Large remote display 100 mm (4") high digits
PreciCura MR sensors for width measurement

We reserve the right to introduce modifications without prior notice.

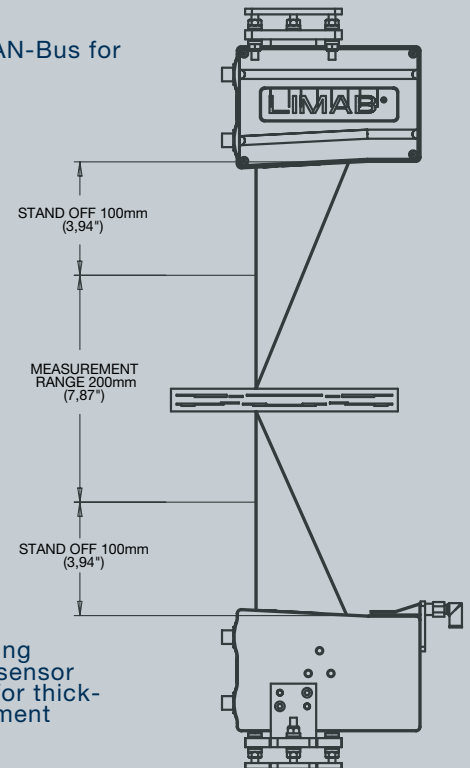

LIMAB were founded almost 30 years ago and has a long tradition of producing innovative laser sensors and measuring systems. The headquarters and manufacturing plant is located in Gothenburg, Sweden. Regional LIMAB offices or representatives operate in various countries outside Sweden for sales and local customer support. Today LIMAB supply in-process non contact laser sensors and turn-key measuring systems to many of the worlds best known companies who produce steel, wood, and building materials.



LIMAB North America Inc.
9301 Monroe Road, Suite B
Charlotte, NC 28270
USA
Tel: 001 (0) 704 321 0760
www.limab.com

LIMAB Oy
Henry Fordin Katu 5K
FIN 00150 HELSINKI
Finland
Tel: 00358 947 80 36 68
www.limab.fi

LIMAB GmbH
Mitterlangstr. 28
D-82178 Puchheim
Germany
Tel: 0049 (0) 89 84058320
www.limab.de

LIMAB UK Ltd
Unit 1J Chelston Business Park
Wellington
Somerset, TA21 9JQ UK
Tel: 0044 (0) 1823 668633
www.limab.co.uk

LIMAB®
CONTROL BY MEASUREMENT

Exportgatan 38 B
SE-422 46 HISINGS BACKA, Sweden
Phone +46 (0)31 - 58 44 00
Fax +46 (0)31 - 58 33 88
sales@limab.se - www.limab.com