

Measurement Solutions for Tube and Pipe Production

Laser based systems for process and quality control



We measure your way to perfection

LIMAB has a long history in providing laser based measurement systems to the steel industry. Today, we can offer solutions for a wide scope of applications in the production of tubes and pipes.

Through our long experience in the steel industry, we have an extensive application knowledge. This ensures that our products meet your and your customers expectations in both performance and quality, which has been proven by installations throughout the world.

LIMAB is developing and manufacturing the complete measurement solution including the laser based sensors. We can offer both 1D and 2D sensor technology. Our product offering covers a wide variety of measurement applications.



LIMAB

Your partner for in-line laser measurements

LIMAB started their activities in the late 70's. Since then, we have focused on developing laser based sensors and systems for a wide scope of steel industry measurement applications. Today, we are considered as a world leader in non-contact, in-line measurements and have installations in all major steel companies, in all parts of the world.

Product development and production is done within the company, which makes it possible to have full control of our products and offer high quality sensors and systems according to the requirements of our customers. We can offer local support through our subsidiaries or our network of certified partners.

Measurement Solutions for the Tube and Pipe Industry

Our measurement systems are available for different locations in the most common tube production processes. We have measurement solutions for both hot and cold tubes in seamless as well as in welding lines.

Seamless Plants

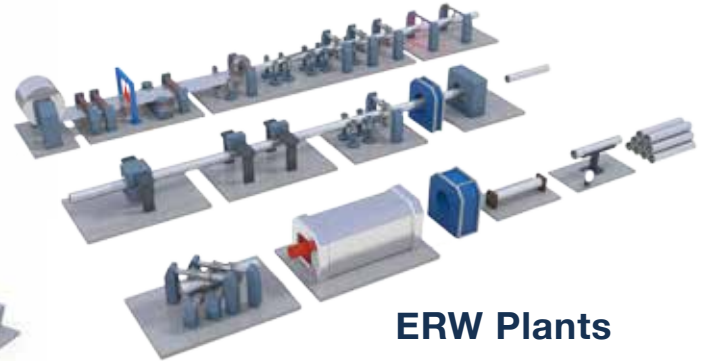
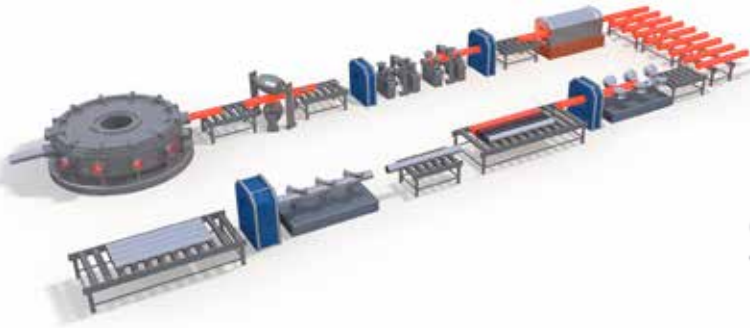

ERW Plants

UOE Plants

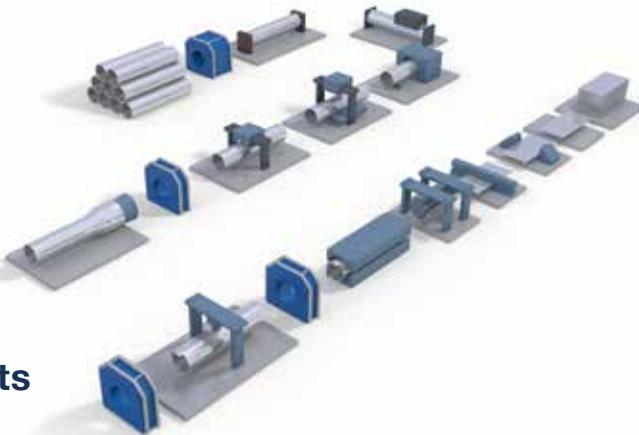

LIMAB gauge location

Production	LIMAB Product	Dimensions	Conditions	Features
Tubes	Sensors	Depends on application	Hot / Cold	1D and 2D laser triangulation
	Compact Systems	Depends on application	Hot / Cold	Based on 2D laser. OD, thickness, width
	TubeProfiler C	Up to Ø 16"	Cold	OD, ovality, length
	TubeProfiler	Up to Ø 60"	Hot / Cold	OD, ovality, shape, length
	TubeProfiler 3D	Up to Ø 60"	Hot / Cold	OD, ovality, full shape, length, weld
	TubeProfiler S	Up to Ø 60"	Hot / Cold	Straightness, OD, ovality, shape, length, weld

TubeProfiler S – Straightness Gauge

The TubeProfiler S is an in-line system measuring end, local and total straightness as well as OD, ovality, shape and length of the tube. It is a perfect tool for optimizing your threading and straightener operation. It is also installed at the finishing line for quality control according to API standards.

The TubeProfiler S consists of three measurement planes, individually equipped with LIMAB sensors. The middle plane will measure the OD, ovality and shape of the tube and in combination with the two outer measurement planes the end, local and overall tube straightness will be measured. The straightness will be expressed both as center line straightness and as surface straightness. For the length measurement we are using a laser Doppler, which is integrated in the system.

The TubeProfiler S can be installed to measure on both hot and cold tubes. It covers a wide range of dimensions up to 60". The system is a very compact in-line gauge occupying only 1.6 meter (5 feet) of space.

Measurement results are displayed on the LIMAB operator software, which can be installed on a multiple of clients. Measurement data are also sent to the plant management system.

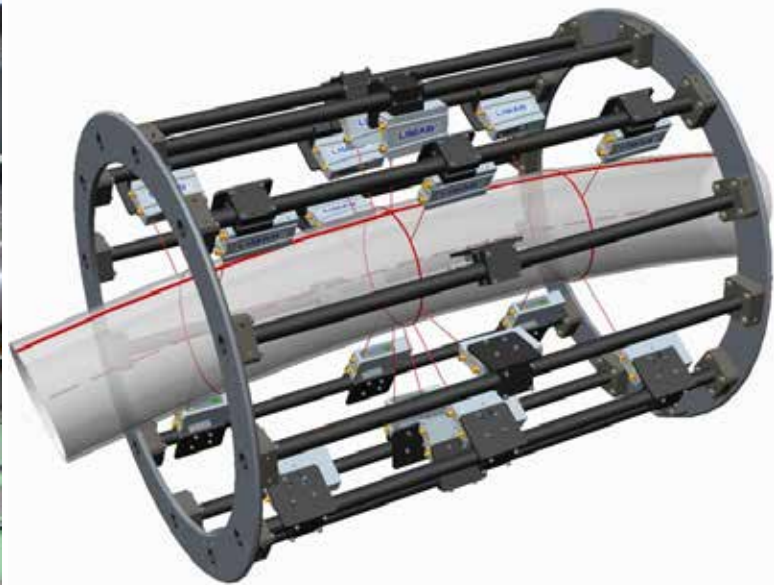

TubeProfiler S

Straightness, OD, Ovality, Shape, Length

The TubeProfiler S is installed directly in the production line. It is intended for process control and quality management purposes. It will secure full traceability of the production, since all dimensional information of the tubes produced are stored in a database.

Measurement concept

Straightness

The TubeProfiler S utilizes LIMAB sensors, which are built in to a robust frame. By combining the three measurement planes and using our highly sophisticated measurement algorithms, the end, local and total straightness of the tube can be accurately measured.

TubeProfiler 3D

The TubeProfiler 3D measures the OD, ovality, full shape, length and weld seam of a tube.

The TubeProfiler 3D integrates our LIMAB 2D sensors, the ProfiCura. These sensors will emit a laser line and by using several lasers placed around the tube, the TubeProfiler 3D will make a complete scanning of the tube circumference. Length is measured by a laser doppler.

The TubeProfiler 3D has versions for hot or cold conditions and dimensions up to 60". It is the perfect tool when looking for a measurement system capable of giving complete dimensional information of the tube.

The measurement results will be displayed by the TubeProfiler 3D operator software, which is user-friendly and can be set-up according to the requirements of the customer. As for all LIMAB systems, data can be communicated to the plant management system for further analysis and actions.

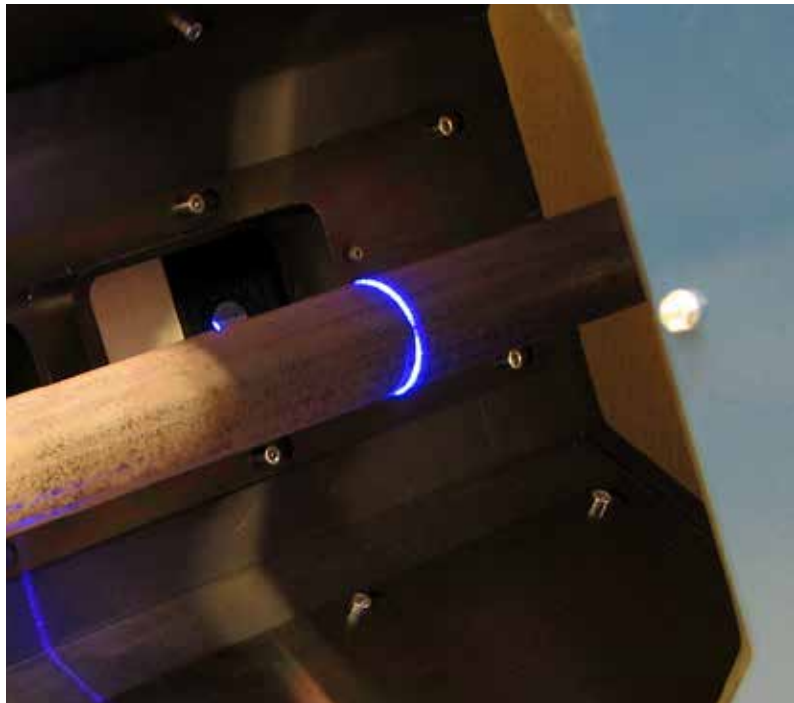
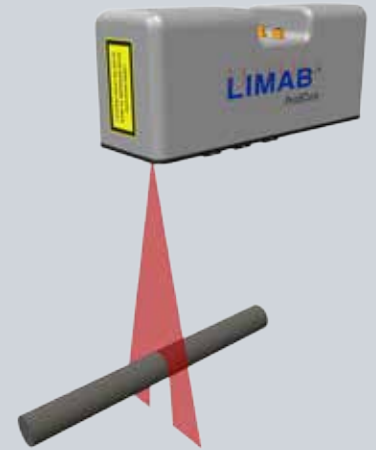

TubeProfiler 3D

OD, Ovality, Full Shape, Length, Weld

The TubeProfiler 3D is a robust in-line system measuring OD, ovality, full shape and length of the tube as well as the shape of the weld seam if present.

Full scanning

Complete tube information

The system integrates the LIMAB ProfiCura 2D sensors, which will scan the complete circumference of the tube. The sensors make fast measurements with a high resolution. Red lasers are used for cold applications, whilst blue lasers are applied for hot conditions.

TubeProfiler / TubeProfiler C

The TubeProfiler measures OD, ovality, shape and length. It comes in different versions for hot or cold conditions and dimensions up to 60". Due to the modularity of the system, we can offer a various of standard versions depending on your requirements and measurement tasks. Our TubeProfiler C is the perfect option for OD and ovality measurement applications for cold tubes at a competitive price.

The TubeProfiler and TubeProfiler C incorporate between 8 to 24, LIMAB PreciCura 1D sensors. These sensors are mounted around the tube inside the frame. The amount of sensors will be decided according to the measurement task and the required performance.

The TubeProfiler takes a minimum of space and can easily be retro-fitted into an existing production line.

The TubeProfiler and TubeProfiler C, like other LIMAB systems, can be delivered with accessories and options that will meet specific local mill requirements in an optimum way, such as sliding table, lifting table, big display and various solutions for ventilation and cooling.

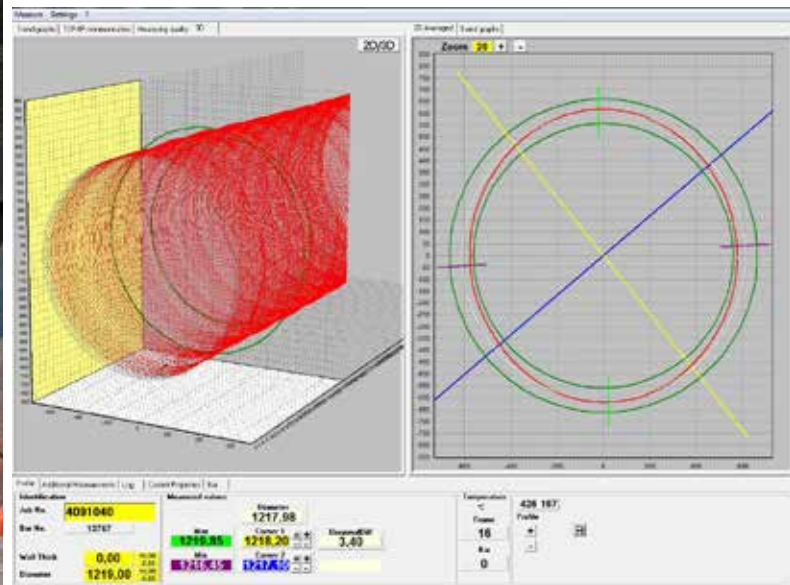

TubeProfiler and TubeProfiler C OD, Ovality, Shape, Length

The TubeProfiler is an in-line system measuring OD, ovality, shape and length.

The TubeProfiler C is specially designed for cold conditions, whilst the TubeProfiler handles both hot and cold applications.

Software key features in LIMAB systems

- 3D and trend graph presentation
- Numerical presentation of key figures
- Tolerance and alarm limits with on-screen warnings
- System set-up and parametrization
- Data logging for quality control
- Communication with plant management system
- Remote service and supervision

Sensors and Compact Systems

Our ProfiCura Smart sensor is a state-of-the-art 2D sensor designed for the harsh environment in steel plants. It has pre-defined measurement modes and integrated communication protocols such as Ethernet, Profibus and Modbus.

LIMAB offers the ProfiCura Smart as a stand-alone sensor or built-in to a compact system including components such as cooling boxes, big displays and fans.

The ProfiCura Smart can be installed to solve several different measurement tasks. One example is to replace a manual caliper measurement of OD with a single laser sensor. Other examples are measurements of weld seams and width measurements of plates. Several ProfiCura Smart sensors can be configured together in a master-slave mode. The sensor set-up is done through an easy-to-use configuration tool.

The ProfiCura can measure on both cold and hot objects as well as on different material qualities.

The ProfiCura range consists of several sensor versions. Depending on the installation location and the object to be measured, different configurations regarding stand-off, measurement range and field-of-view can be selected.



Compact Systems

Replace your manual measurement

By building a compact systems based on our ProfiCura sensor and other system components, it is possible to replace most of the existing manual measurements. One example is to replace a OD caliper measurement of a hot tube.

ProfiCura Smart

Pre-defined measurement modes

The ProfiCura Smart has pre-defined and selectable measurement modes. The sensor has a large capacity in terms of calculation capability and memory, which makes it possible to have all measurement algorithms integrated in the sensor. Analogue, digital or different fieldbuses, such as Profibus and Modbus, are available as direct output of the measurement results.

LIMAB Measurement Solutions for Tubes and Pipes

World wide presence

LIMAB has a world wide presence for sales and support, either by subsidiaries or certified partners.



We reserve the right to introduce modifications without prior notice

LIMAB – the complete measurement solution provider for the tube and pipe industry

Our core capability resides in our ability to deliver effective laser scanning systems for our customers. Through our experience and understanding of your needs we engineer and produce the right process measurement solutions that will improve your production yield.

LIMAB was founded almost 40 years ago and has a long tradition of developing and manufacturing laser based technology. We supply laser guide lines, laser sensors and complete systems for dimensional and profile measurement in steel mills, panel production and saw mills. Headquarter and manufacturing plant is located in Gothenburg, Sweden. LIMAB has regional offices in the USA, UK and Germany as well as approved distributors and partners in other regions.



LIMAB North America Inc
9301 Monroe Road, Suite B
Charlotte, NC 28270
USA
Tel: +1 704 321 0760
www.limab.com

LIMAB GmbH
Mitterlangstr. 28
D-82178 Puchheim
Germany
Tel: +49 (0) 89 84058320
www.limab.de

LIMAB UK LTD
Unit 3L, Westpark 26
Wellington
Somerset, TA21 9AD, UK
Tel +44 (0) 1823 668 633
www.limab.co.uk



Almedalsvägen 15
SE-412 63 Göteborg
Sweden
Phone +46 (0)31-58 44 00
Fax +46 (0)31-58 33 88
sales@limab.se
www.limab.com