

## ***XLR30 Laser Distance Measuring Module. Precise. Robust. Reflectorless.***

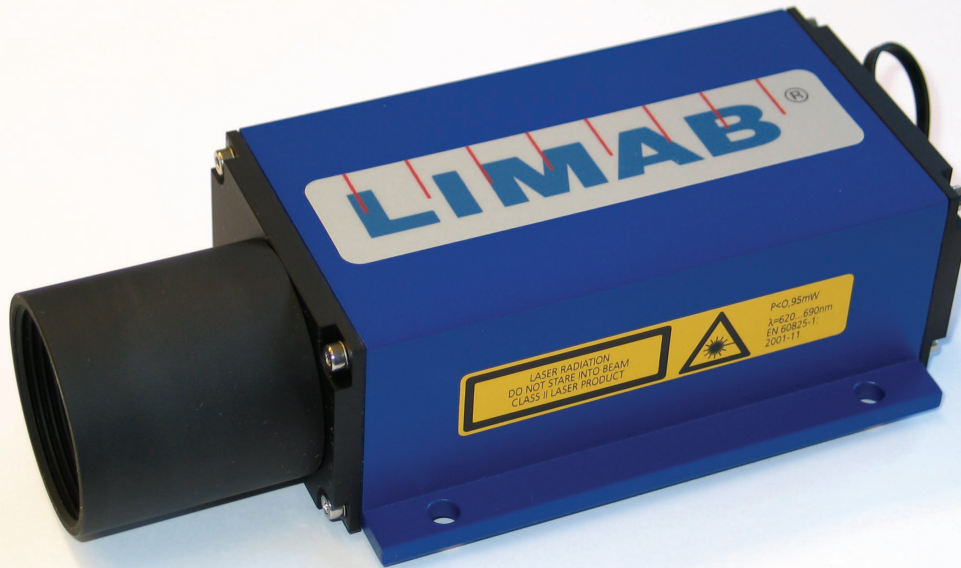

***Measures distances with millimetre accuracy.***

***Precisely defines positions.***

***Registers movements.***

### **Measuring system:**

The XLR30 provides an optoelectronic distance measuring module for industrial applications.

Non-contact measure by principle of comparative phase shift measurement.

Easy to install due to visible laser.

High measuring rate of 50 Hz.

RS 232 or RS 422, data interface.

Programmable digital switching output.

Programmable analog output from 4 mA to 20 mA.

External trigger input.

### **Features:**

Laser class 2 for safe operation.

Non-reflector measurement.

Measures on all types of surface with millimetre accuracy.

Allows field bus integration (external).

Dust- and waterproof protection (IP 65).

Low power consumption.

Compact design.

Easy to customise to application by using the parameter settings.

### **Application:**

Log gap sensing.

Monitoring of delivery systems and crane equipment.

Distance measurement.

Position measurement.

Fill-level measurement.

Security applications.

Position monitoring for moving objects.

Monitoring of hoisting equipment / lift measuring.

Elevator positioning.

Parts detection.

# XLR30 Laser Distance Measuring Modul.

Measuring range*1:	Distances greater than 100 m (328ft) are possible depending on the surface reflectance, 0.1 to 30 m (0.3ft to 98ft) on natural surface
Measuring accuracy*2	± 3 mm (+15 °C to +30 °C), ± 5 mm (-10 °C to +50 °C) ± 0.12" (+59 °F to +86 °F), ± 0.2" mm (+14 °F to +122 °F)
Measuring resolution:	0.1 mm (0.0039")
Measuring time:	0.16 to 6 s, 20 ms (50 Hz) on white surface
Repeatability:	≤0.5 mm (0.02")
Laser divergence:	0.6 mrad
Laser classification:	≤1 mW under IEC 825-1 / EN 60825, laser class 2
Wavelength:	650 nm (visible)
Supply voltage:	DC 10 ... 30 V
Connection:	12-pin-connector (BINDER series 423)
Data interface:	RS 232 or RS 422, 2,4 / 4,8 / 9,6 / 19,2 / 38,4 kBaud, 8N1, no handshaking, ASCII protocol configuration of parameters to be measured (e. g. scale, time to measure), configuration of analog and digital output, trigger input and turn-on behavior, output of distance readings or error messages, query for internal module temperature.
Operating modes:	Distance tracking, single measurement, external triggering
Switching output:	HIGH = UV, - 2 V, LOW < 2 V, with 0.5 A load capacity, threshold and hysteresis changeable, invertable
Analog output:	4 mA to 20 mA, distance boundary adjustable, defect conditions adjustable, load resistance ≤ 500 Ω
Trigger input:	Trigger edge and trigger delay adjustable, trigger pulse max 24 V
Operating temperature:	-10 °C to +60 °C (+14 °F to +140 °F)
Storage temperature:	-20 °C to +70 °C (-4 °F to +158 °F)
Phys. dimensions (L x W x H):	(212 mm x 96 mm x 50 mm) (8.3" x 3.8" x 2.0")
Internal protection class:	IP 65
EMV:	EN 61000-6-2, EN 55011

\*1 dependent on target reflectivity, stray light influences and atmospheric conditions  
\*2 statistical spread 95%

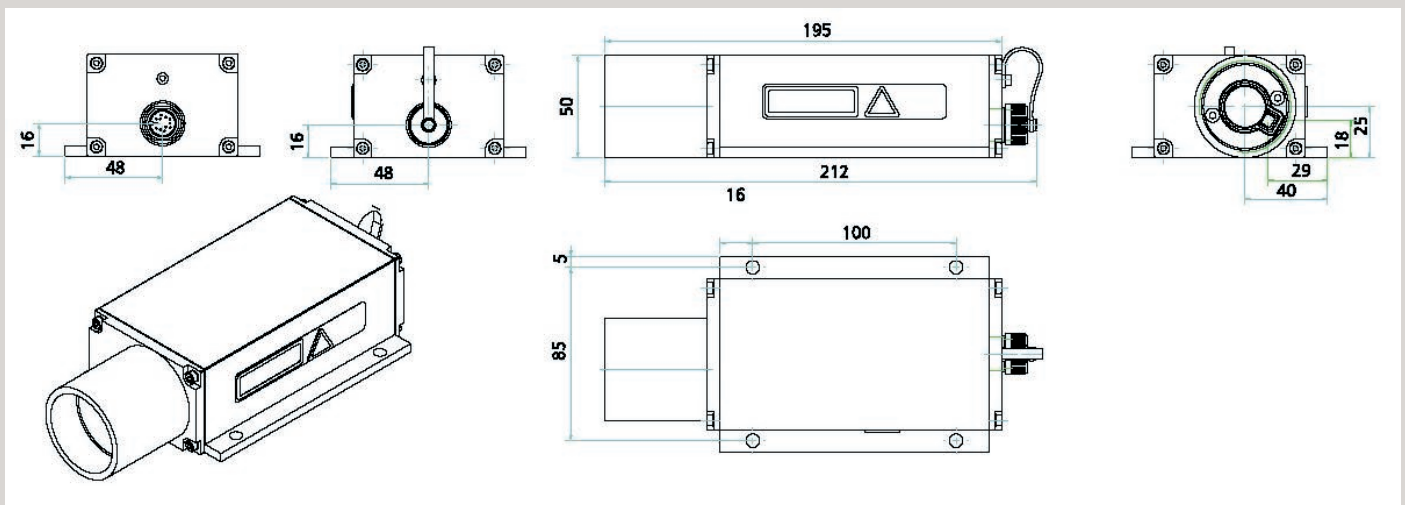

We reserve the right to introduce modifications without prior notice.

## LIMAB North America inc.

9301 Monroe Road, Suite B  
Charlotte, NC 28270  
Phone: +1-(704) 321-0760  
Fax: +1-(704) 321-0761  
sales@limab.com  
www.limab.com

## LIMAB Oy

Henry Fordin katu 5K  
FIN 00150 HELSINKI  
Phone: +358 947 80 36 68  
Fax: +358 947 80 36 67  
pekka.haimi@limab.fi  
www.limab.com

## LIMAB GmbH

Mitterlängstraße 28  
D-82178 PUCHHEIM  
Phone: +49(0)89-84 05 83 20  
Fax: +49(0)89-84 05 83 21  
michael.karlsson@limab.de  
www.limab.de



Exportgatan 38 B  
SE-422 46 HISINGS BACKA, Sweden  
Phone +46 (0)31 - 58 44 00  
Fax +46 (0)31 - 58 33 88  
sales@limab.se  
www.limab.com